

C80-H442.01 S5W2

Pneumatic taper change

Item no. **11504002**

HF-Spindle for high-speed milling, -grinding, -drilling, -engraving

Bearings

Hybrid ball bearing (pcs)	1 (front)
Steel ball bearing (pcs)	1 (rear)
Lifetime lubricated	maintenance free

Motor

Motor technology	3-phase asynchronous drive (no brushes or sensors)
Frequency	700 Hz
Motor poles (pairs)	1
Rated rotation speed	42.000 rpm
Acceleration/braking value Per second	10 000 rpm (other values by consultation)

Power values

Liquid cooled

	Pmax./5s	S6-60%	S1-100%	
Rated power	5,5	4,1	3,4	[kW]
Torque	2,04	1,43	0,82	[Nm]
Voltage	210	210	210	[V]
Current	23,4	16	13	[A]

C80-H442.01 S5W2

Pneumatic taper change
Item no. 11504002

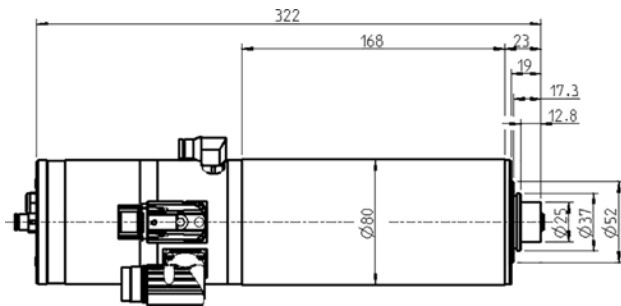

Dimensions

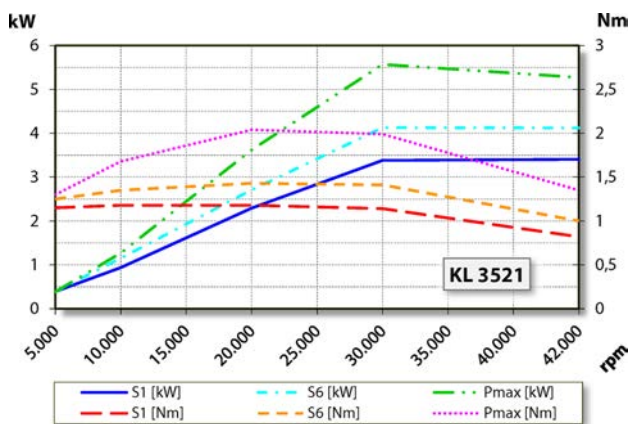

Performance Diagram

Liquid cooled

Measurement of power is funded by in-house testing.

Characteristics

Motor protection	PTC 130°C
Housing	Stainless steel
Housing diameter	80 mm
Cooling	Liquid cooled
Ambient temperature	+ 10°C ... + 45°C
Sealing air	
Protection category (sealing air turned on)	IP54
Taper cleaning	
Tool change	Pneumatic taper change
Tool Holder	HSK-E 25
Tool change monitoring	inductive
3 positions	clamped, unclamped, ejected
Clamping range up to	10 mm
Clockwise and anticlockwise	
	9-pin (SpeedTEC) (motor phases)
Coupler plug	12-pin (sensors)
Weight	~ 6,5 kg
Inner taper run out	< 2 μ
Axial run-out	< 2 μ