

## Z42-M160.20 K1S2

### Manual tool change

Item no. **10201045**

HF-Spindle for high-speed milling, -grinding, -drilling, -engraving

### Bearings

Hybrid ball bearing (pcs)	2
Lifetime lubricated	maintenance free

### Motor

Motor technology	3-phase asynchronous drive (no brushes or sensors)
Frequency	1.000 Hz
Motor poles (pairs)	1
Rated rotation speed	60.000 rpm
Acceleration/braking value Per second	10 000 rpm (other values by consultation)

### Power values

#### Uncooled

	Pmax./5s	S6-60%	S1-100%	
Rated power	0,8	0,5	0,3	[kW]
Torque	0,147	0,091	0,086	[Nm]
Voltage	93	78	54	[V]
Current	8,4	5,3	5,5	[A]

**Z42-M160.20 K1S2**

Manual tool change  
Item no. **10201045**

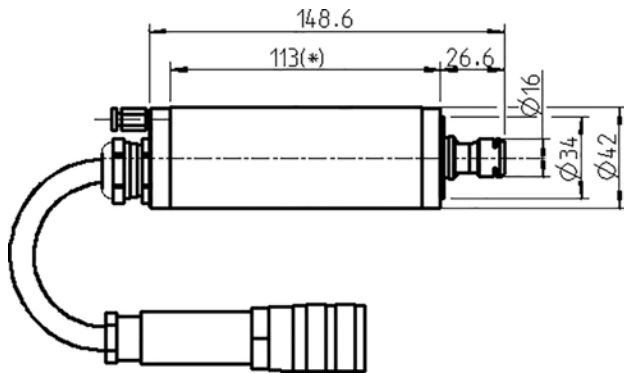

Dimensions

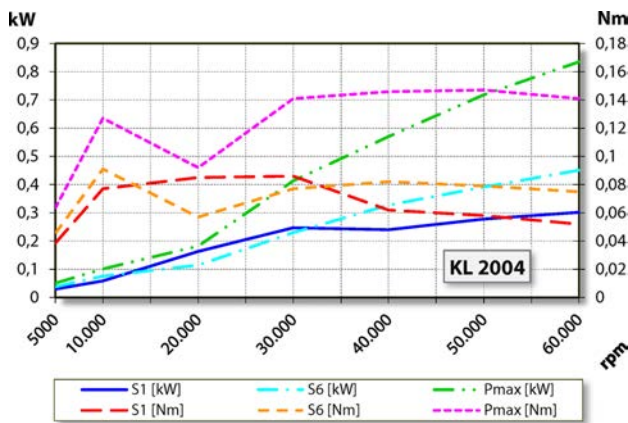

Performance Diagram

Uncooled

Measurement of power is funded by in-house testing.

**Characteristics**

Speed sensor	Differential magneto resistor (TTL) Number of signals = 6
Motor protection	PTC 160°C
Housing	Aluminium
Housing diameter	42 mm
Cooling	Uncooled
Heat dissipation	Via the spindle holder
Housing temperature	< + 45° C
Ambient temperature	+ 10°C ... + 45°C
Sealing air	
Protection category (sealing air turned on)	IP54
Tool change	Manual tool change
Collet type	ER 11 Optional accessories
Clamping range up to	7 mm (9/32")
Clockwise	
Coupler plug	7-pin plastic Cable length 1 m
Weight	~ 1 kg
Inner taper run out	< 1 µ